

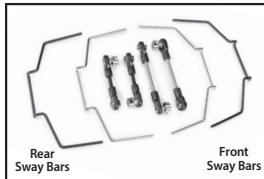

## Steering Sway Bar Instructions

Covers Part #9098



### Kit Contents:

- Front sway bar (black, stiff)
- Front sway bar (silver, soft)
- Rear sway bar (black, stiff)
- Rear sway bar (silver, soft)
- Front and Rear Linkages (4)
- 3x18mm button-head cap screws (BCS) (4)
- 3x3mm set screws (GS) (4)

### Installation:

1. Install the front linkages on each end of the front sway bar using the included 3x3mm GS (2).
2. Disconnect the front sway bar mount from the front bulkhead. Place the front sway bar assembly into the sway bar mount, and then reattach mount.
3. Connect the sway bar links to the front suspension arms using the included 3x18mm BCS (2).
4. Install the rear linkages on each end of the rear sway bar using the included 3x3mm GS (2).
5. Disconnect the rear sway bar mount and wing. Place the rear sway bar assembly into the sway bar mount, and then reattach the wing and mount.
6. Connect the sway bar links to the rear suspension arms using the included 3x18mm BCS (2).

### Front Sway Bar

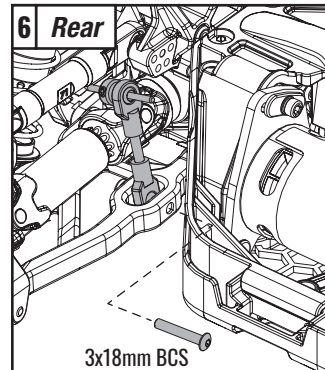
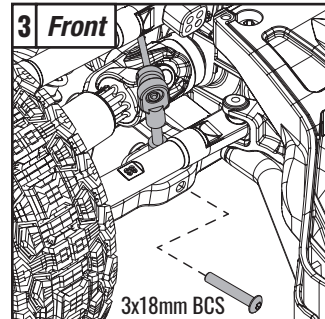
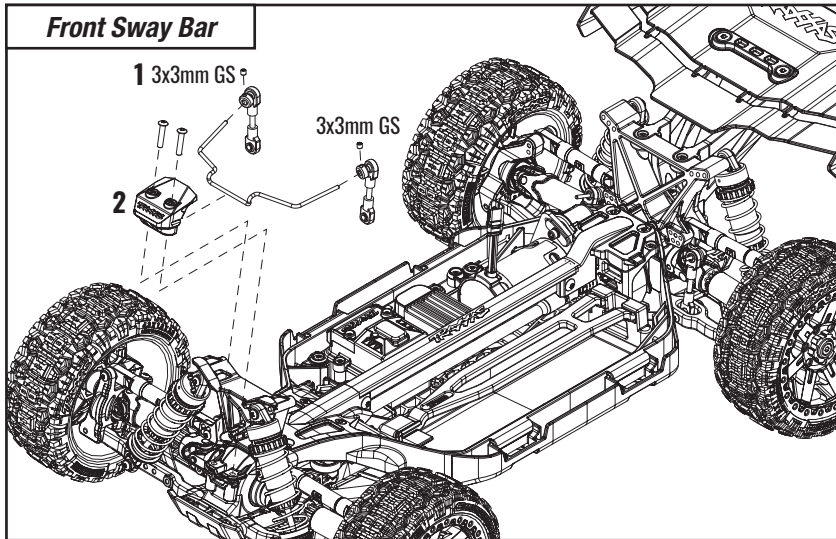

### Rear Sway Bar

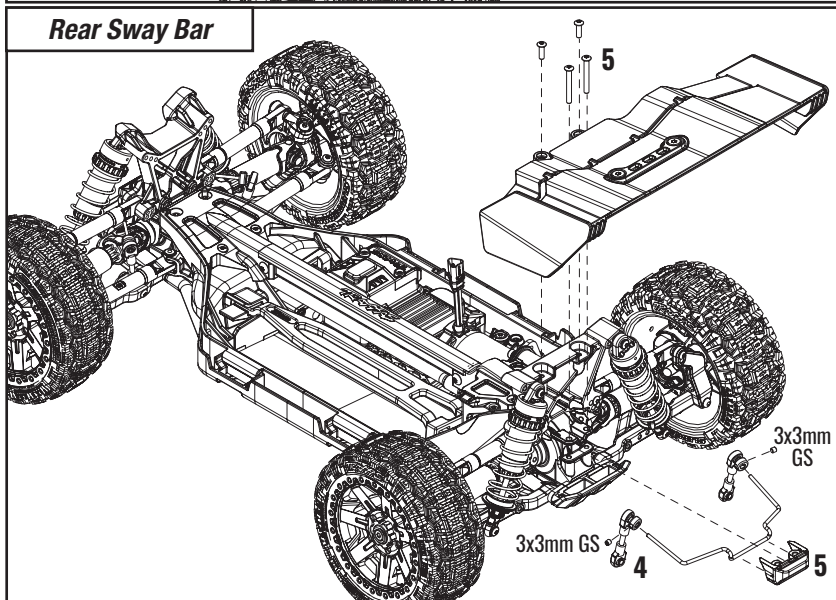



Visite la página TRAXXAS.com/manuals para descargar el instrucciones en su idioma.

Auf TRAXXAS.com/manuals können Sie anleitung in Ihrer Sprache downloaden.

## Steering Sway Bar Instructions

Covers Part #9098

### Recommended Settings and Adjustments

- The sway bar set includes two different front and rear sway bars. The thicker of the two (black) is stiffer and will further reduce body roll in cornering.
- Always adjust the left and right sway bar links equally to prevent suspension tweak.
- The adjustable hollow balls can be adjusted closer to or further from the sway bar mount (pivot point) to change roll stiffness and fine tune the sway bar's response for different track conditions. Closer to the pivot point increases roll stiffness; further from the pivot point decreases roll stiffness.

### For smooth surfaces with high traction:

- Try black front and rear sway bars. Adjust linkage placement for stiffer response (closer to pivot point on sway bar).

### For rough surfaces with low traction:

- Try silver front and rear sway bars. Adjust linkage placement for softer response (away from pivot point on sway bar).

### To reduce understeer (pushing in corners):

- Try silver front sway bar. Adjust front linkage placement for softer response (away from pivot point on sway bar).
- Try black rear sway bar. Adjust linkage placement for stiffer response (closer to pivot point on sway bar).

### To reduce oversteer (loose in corners):

- Try black front sway bar. Adjust linkage placement for stiffer response (closer to pivot point on sway bar).
- Try silver rear sway bar. Adjust front linkage placement for softer response (away from pivot point on sway bar).

If you have questions or need technical assistance, call Traxxas at

**1-888-TRAXXAS**

(1-888-872-9927) (U.S. residents only)